

THIS DRAWING IS UNPUBLISHED. RELEASED FOR PUBLICATION, 19 .
 © COPYRIGHT 19 BY AMP INCORPORATED. ALL INTERNATIONAL RIGHTS RESERVED.

LOC	DIST	P	F	REVISIONS				
AF	50			ZONE	LTR	DESCRIPTION	DATE	APPD
					B	REVISE PER ECN 0G1A-0178-98	07AUG98	SU/KR

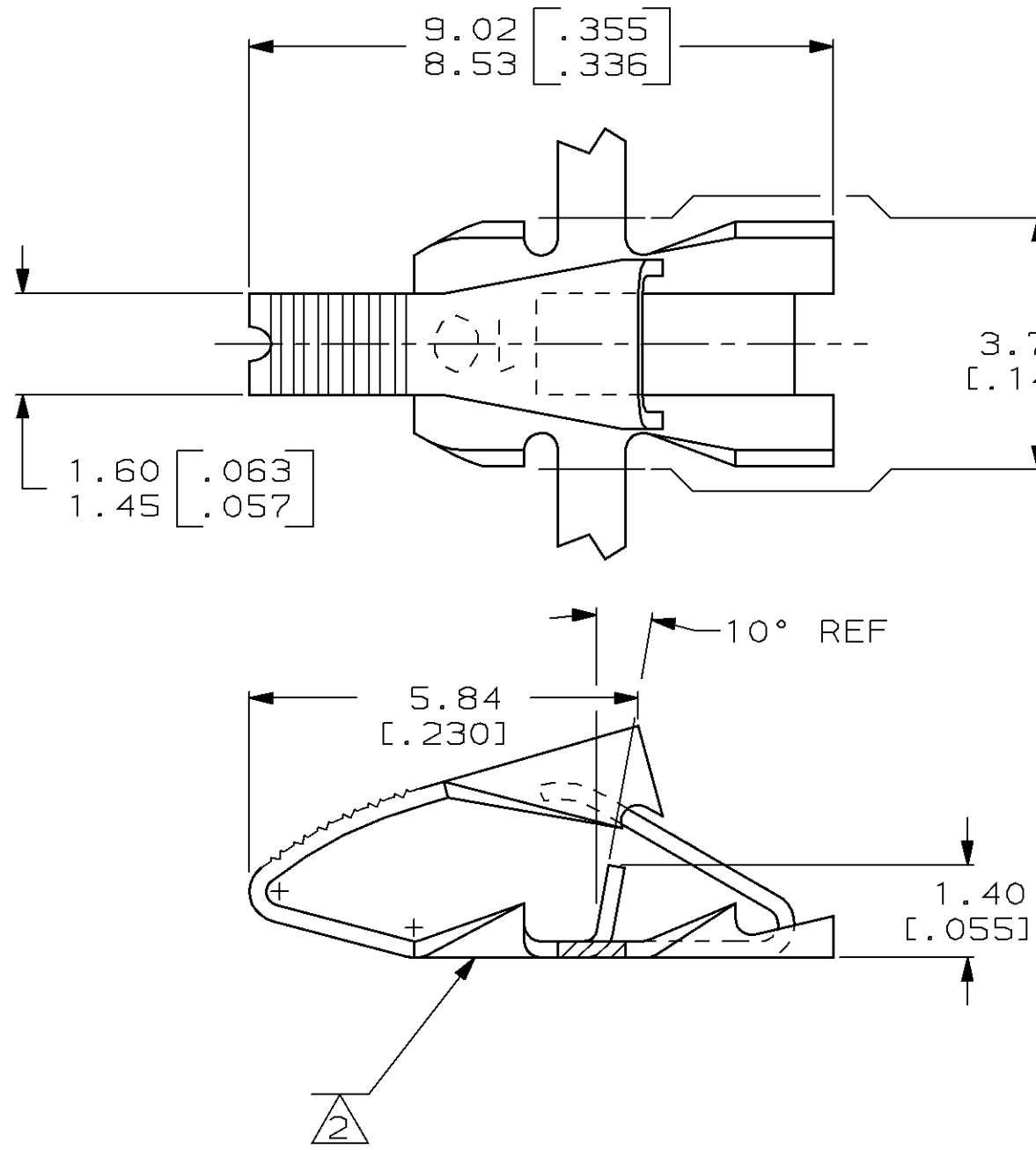

- 1 CONTINUOUS STRIP ON REELS WITH TERMINALS LOCATED ON 6.10±0.08 [.240±.003] CENTERS.
- 2 IDENTIFICATION NUMBER (10) FOR MAGNET WIRE RANGE.

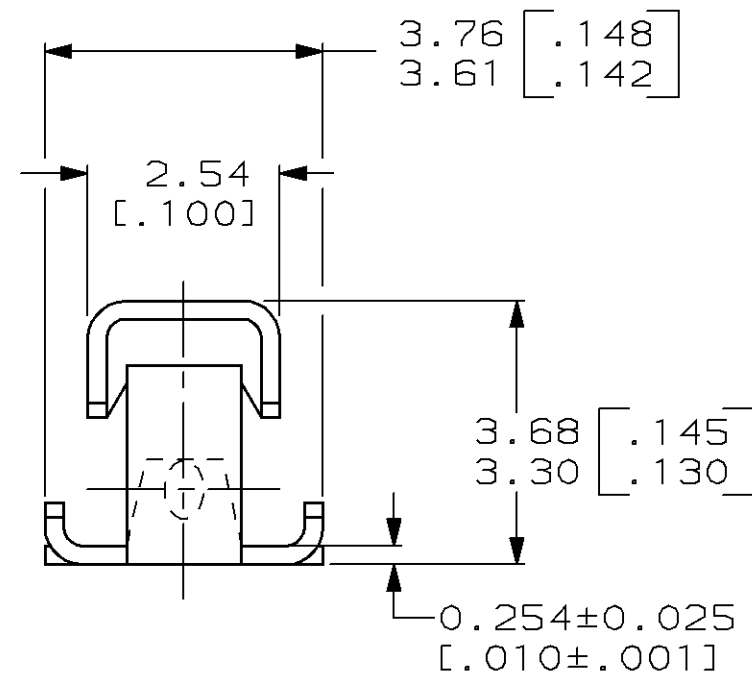

PROPOSED DESIGN
 NOT RELEASED FOR
 PRODUCTION

THIS DRAWING IS A CONTROLLED DOCUMENT FOR AMP INCORPORATED. IT IS SUBJECT TO CHANGE AND THE CONTROLLING ENGINEERING ORGANIZATION SHOULD BE CONTACTED FOR THE LATEST REVISION.

0.05-0.13mm [#44-#36] AWG		63795-1	
COPPER MAGNET WIRE RANGE		PART NUMBER	
DO NOT SCALE PRINT, UNLESS SPECIFIED. DIMENSIONS IN mm [INCHES]. TOLERANCES ON: 2 PLC DEC ± 0.25 [.010] 3 PLC DEC ± - ANGLES ± -		AMP AMP Incorporated Harrisburg, PA 17105-3608	
MATERIAL H02 BRASS		NAME TERMINAL, POKE-IN, MINI MAG-MATE™	
FINISH 0.002032 [.000080] MIN TIN PER MIL-T-10727		SIZE B	
DR 15/JUN/94 MICHAEL S. FEHER CHK 15/JUN/94 JEFF R. RUTH APPD 15/JUN/94 ALEX HUNT III APPD 15/JUN/94 TERRY L. SHUTTER PRODUCT SPEC 108-2016 APPLICATION SPEC 114-2047 WEIGHT -		CAGE CODE 00779	
		DRAWING NO C-63795	
		SCALE 10:1	
		SHEET 1 OF 1	